

J. S. HANSEN & C. D. WAINWRIGHT.
MACHINE FOR CORRUGATING TUBES.

No. 434,060.

Patented Aug. 12, 1890.

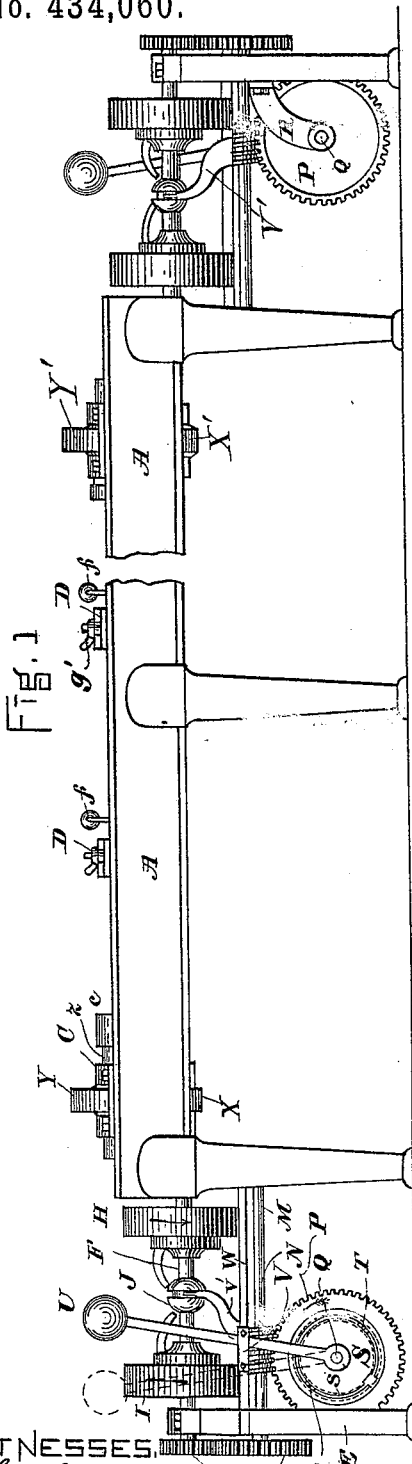
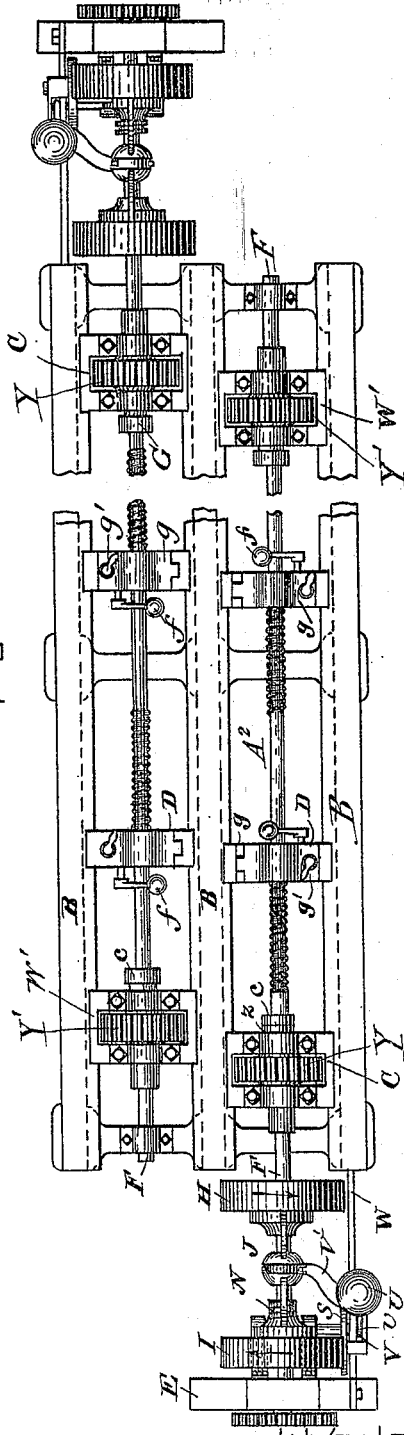

FIG. 1

FIG. 2



WITNESSES
L. M. Miller
John R. Snow

INVENTORS.
John S. Hansen
Charles D. Wainwright
 by their attorneys,
J. C. McQuaid

J. S. HANSEN & C. D. WAINWRIGHT.
MACHINE FOR CORRUGATING TUBES.

No. 434,060.

Patented Aug. 12, 1890.

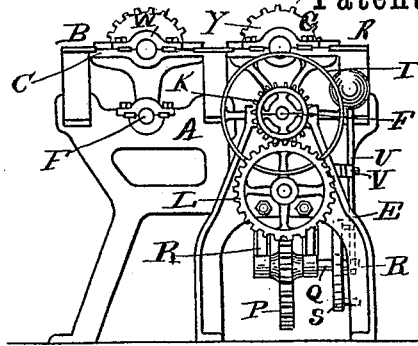

Fig. 3.

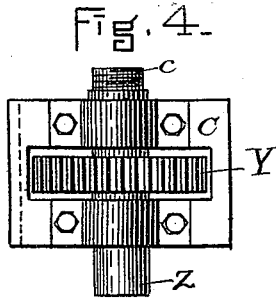

Fig. 4.

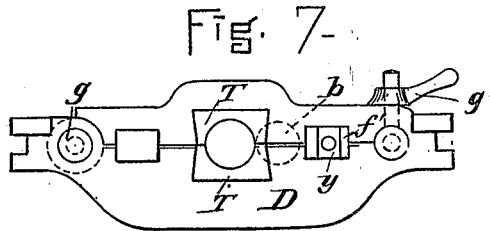

Fig. 7.

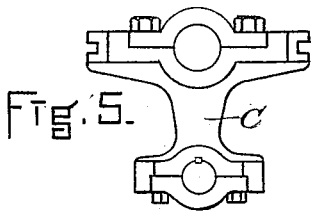

Fig. 5.

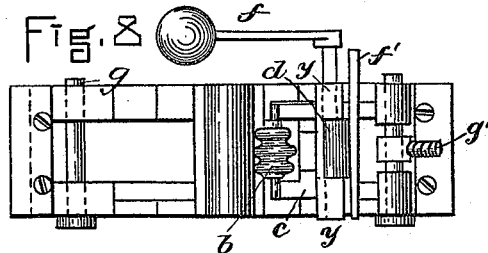

Fig. 8.

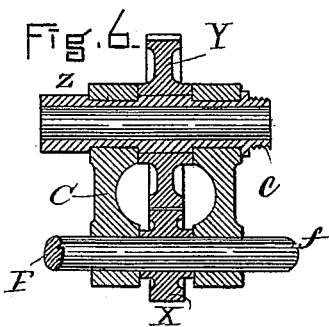

Fig. 6.

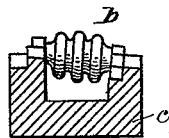

Fig. 9.

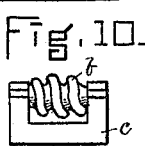

Fig. 10.

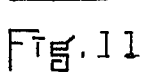

Fig. 11.

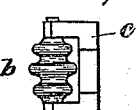

Fig. 12.

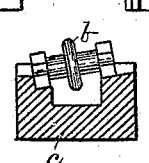
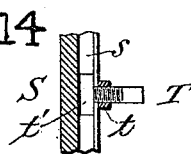

Fig. 13.

WITNESSES.

L. W. Möller.
John R. Snow

Fig. 14



INVENTORS.

John S. Hansen
Charles D. Wainwright
by their attorney
J. C. Maynard.

UNITED STATES PATENT OFFICE.

JOHN S. HANSEN AND CHARLES D. WAINWRIGHT, OF MEDFORD, MASSACHUSETTS, ASSIGNORS, BY MESNE ASSIGNMENTS, TO THE WAINWRIGHT MANUFACTURING COMPANY OF MASSACHUSETTS.

MACHINE FOR CORRUGATING TUBES.

SPECIFICATION forming part of Letters Patent No. 434,060, dated August 12, 1890.

Application filed March 30, 1889. Serial No. 305,481. (No model.)

To all whom it may concern:

Be it known that we, JOHN S. HANSEN and CHARLES D. WAINWRIGHT, both of Medford, in the county of Middlesex and State of Massachusetts, have invented a new and useful Improvement in Machines for Corrugating Tubes and the Like, of which the following is a specification, reference being had to the accompanying drawings, in which—

Figure 1 is a side elevation, and Fig. 2 a plan, of one form of a machine embodying our invention. Fig. 3 is an end view thereof. Fig. 4 shows a gear. Figs. 5, 6, 7, and 8 show different views of parts of the machine, hereinafter explained; and Figs. 9, 10, 11, 12, and 13 show different forms of the corrugating-tool. Fig. 14 shows a detail view of one of the pins, hereinafter explained.

Our invention is a machine for corrugating pipes, tubes, and the like, and is an improvement on the machine described in Green and Ashbury's English patent, No. 1,980, of 1860. In that machine the tube to be corrugated is secured in a head-stock and supported in a sleeve which has a slot, through which a corrugating-disk carried by a fork projects to engage the pipe. The slotted supporting-sleeve and the disk-carrier are fixed in relation to each other, and both sleeve and disk-carrier are mechanically connected with the head-stock, so that its rotation compels the supporting-sleeve and corrugating-disk carrier to move positively and in time with the rotating head-stock. This positive feed of the corrugating-tool is highly objectionable, because it frequently results in straining and tearing the material of which the tube to be corrugated is made. We have discovered that this objectionable feature may be obviated by making the tube-support free to slide; and our invention consists in the combination of a head-stock, a tube-support, and a corrugating-tool, which may be either a disk or a corrugated corrugating-tool, with a support and tool-carriage, which is free to move and is not fed positively—that is, the striking novelty of our invention is to feed the corrugating-tool and tube-support by the contact of the tube with the corrugating-tool.

Minor features of our invention will be set forth hereinafter.

In the drawings, in which we show the best form of machine embodying our invention now known to us, A is the frame, on top of which is the bed B, upon which a preferred form of carriage D is mounted, so as to slide very freely.

C is the head-stock, (see Figs. 2, 4, 5, and 6,) provided with a chuck *c* to hold one end of the tube. Its shaft *z* is made hollow, (see Figs. 5 and 6,) so as to allow the tube to be easily handled.

Y is a cog mounted on the shaft Z and engaging with the gear X, mounted on the shaft F, which is journaled in the frame E. The gear X is provided with a feather, which fits into the groove *f* in the shaft F, so that the head-stock and gear X may be moved longitudinally on the shaft, and yet will rotate with it.

H I are pulleys rotated in opposite directions from the source of power, and each in turn supplying power to rotate the shaft F, upon which they are loosely mounted. The shaft F is rotated from either of these pulleys by means of a clutch J, which rotates with the shaft F and is capable of engaging with either of said pulleys or with neither of them, so that the shaft F shall be rotated from either one of said pulleys or be stopped, as desired. The clutch J is thrown by means of the overweighted lever U, which is loosely fulcrumed on shaft Q, hung in bearings R R from the frame E.

V is a slotted slide mounted to slide on the bar W. The lever U passes through its slot *v*. To the slide is attached the arm V', which engages with the clutch J, so that by moving the slide the clutch will be caused to engage with one of the pulleys H I or with neither. Upon the shaft Q is mounted the disk S, provided on its face with the circular groove *s*, in which the pins T are adjustably secured, their heads *t'* lying in the slotted groove *s* and sliding freely therein to any desired position, each pin being held in place by a nut *t*, which screws upon it, so as to bind tightly against the face of the disk S. This will be

understood by reference to Fig. 12, which is a cross-section of the disk S, showing the groove *s* and one of the pins T in place. These pins T project from the disk, so as to strike the lever U and throw it over. As the lever U is thrown over by one of these pins from, say, the position shown in Fig. 1, its momentum carries with it the slide V, which, by means of the arm V', moves the clutch J away from the pulley H and into contact with the pulley I, provided it is not stopped in such a position as to carry the clutch only half-way between the pulleys and so stop the lathe. Power is applied to the shaft Q by means of the worm-gear P, which engages with the worm N on the shaft M, and motion is transmitted to shaft M from the main shaft F by means of the gears K L.

The above mechanism is for the purpose of rotating for a certain length of time the tube which is held in the clutch in the head-stock C, and then automatically reversing the motion of the tube for the purposes to be described below. It is an especially convenient mechanism for the purpose because of its quickness of movement; but other forms may be used to give the desired motion to the tube.

The carriage D (shown in Figs. 7 and 8) contains the support in which the tube is held, and Figs. 9, 10, 11, 12, and 13 show different forms of corrugating-tools, Figs. 9, 10, and 11 showing corrugated corrugating-tools, while Figs. 12 and 13 show a single disk. The form of carriage shown consists of two parts: the lower part or body which rests on the bed-plates B and the cover hinged to the body at *g* and fastened by the screw-bolt *g'*. The form of tube-support shown also consists of two parts or blocks, one in the cover and one in the body, which, when the cover is shut upon the carriage, together form a passage through which the tube can pass. The diameter of this passage should depend upon the diameter of the tube to be corrugated. Its interior surface should be such as to furnish sufficient support to the exterior of the tube to prevent it from bulging outwardly or collapsing. We prefer to make it cylindrical, as shown, and the two-part support shown is the most convenient form of support now known to us.

The tube-support is slotted in one side to receive the corrugating-tool. The block *c* is set in bearings, so that it will slide toward and from the axis of the sleeve through this slot, its movements being preferably governed by the cam *d*, the shaft of which is mounted in bearings *y*. A weighted crank *f* compels the cam to bear upon the movable wedge *f'* and force the tool against the tube. This same result may be attained in other well-known ways, as by springs or set-screws. In using this preferred form of our machine one end of the tube is plugged to prevent its being collapsed by the pressure of the chuck, and it is then secured in the chuck in the head-stock C. That part of the farther end

of the tube where the corrugation is to begin is laid into the open carriage, and the cover of the carriage is closed and fastened by the screw-bolt *g'*. The tube is now rotated in contact with the corrugating-tool. As the tool is forced against the tube the carriage will feed itself along the bed B toward the head-stock, the tool working on the tube and forming corrugations thereon. The pins T are so set that when the carriage has reached the other end of the tube one of the pins will strike the lever U and throw it over into its other position. The momentum of the lever U will cause it to carry with it the valve V, which by means of the arm V' disengages the clutch J from one of the pulleys H I and engages it with the other, thereby reversing the movement of the lathe and causing the movement of the carriage to be reversed and the carriage to travel back until the other pin T strikes and throws over the lever U with the same result as before. By causing the carriage and tool to pass backward and forward over the tube a corrugation is gradually made, the tool at first indenting the tube but slightly, and then with each passage over the tube making a deeper and deeper indentation. By this means but slight strain is given to the metal during the process. While this corrugating is going on the tube is gradually shortened, and it is therefore evident that this process cannot be undertaken when the feed of the tool and tube in relation to each other is positive. The reversing of the shaft F also reverses the disk S because of the connecting mechanism P, N, M, L, and K, above described. When the tube A² has been sufficiently corrugated, the lever U, on being thrown by a pin T, is caught and held in any desired way in a nearly vertical position, thus disengaging the clutch J from both pulleys. The continued bearing of the tool upon the tube corrugates it in the desired manner, the symmetrical shape of the tube being preserved by use of the sleeve. Two or more carriages may be used upon the same tube, as shown, to corrugate it at the same time in different places. If the tube be long, a tail-stock W', attached by a suitable clutch to the tail end of the tube, is useful in keeping the tube from twisting. The tail-stock should be free to move upon the bed B and its chuck should be rotated from the shaft F. The end of the tube which sets into the chuck of the tail-stock should be plugged, as before described.

In the drawings is shown a convenient arrangement of two separate machines side by side, such that one man can take care of both, though each is entirely separate and distinct and can corrugate a tube of a different size from the other.

The tube-support should be sufficiently cylindrical to present a substantially-cylindrical bearing-surface, which shall cause the tube to keep its shape while it is being corrugated by the tool.

Any desired form of clutch may be used in

connection with the weighted lever for the purpose described.

It will be readily understood by all skilled in the art that for some purposes the single disk is preferable to the corrugated corrugating-tools, while for other purposes the corrugated corrugating-tools are preferable. Where it is desired to give the pipe a good finish, the corrugated corrugating-tool is desirable, because the corrugations thereon act as formers and polishers.

What we claim is—

1. The herein-described combination of a head-stock, tube-support, and corrugating-tool with a tube-support and corrugating-tool carriage fed by the contact of the tube and tool, substantially as and for the purpose set forth.

2. In combination with the head-stock, a carriage D, free to slide upon the lathe-bed in either direction and provided with a tube-support, and the corrugating-tool located therein, all arranged together substantially as and for the purposes set forth.

3. The carriage above described free to slide upon the lathe-bed and provided with a tube-support and a rotary corrugating-tool mounted in bearings on said carriage, all as set forth.

4. The tube-support and the tool mounted

in adjustable bearings, in combination with the cam located behind said bearings and mounted on a crank-shaft provided with a weighted crank, substantially as and for the purpose described.

5. In a corrugating-machine provided with a head-stock, a tail-stock, and a tool-carriage free to move upon the lathe-bed, as described, said carriage having a corrugating-tool located therein, substantially as described, in combination with mechanism whereby said machine may be adapted to corrugated tubes of different lengths, said mechanism consisting of the clutch J, the overweighted lever U, the slide V, and its arm V', the grooved disk S, provided with pins T, adjustably arranged therein, and the worm-gear P N, all arranged together and operated substantially as and for the purposes set forth.

6. In a corrugating-machine, a carriage free to move on the lathe-bed provided with a tube-support and a corrugating-tool projecting into the tube-rest, all substantially as and for the purposes set forth.

JOHN S. HANSEN.

CHARLES D. WAINWRIGHT.

Witnesses:

EDWARD S. BEACH,

JOHN R. SNOW.